

**Study Guide
For new applicants
pursuing Journeyman status in
I.A.T.S.E. Local 470
North-eastern and Central Wisconsin**



Notice to applicant:

This guide contains multiple choice, fill in the blank, and true or false questions. Only information taken from the following pages will be used on the full card examination. Keep written answers as concise as possible. This guide, as well as the final test, will quiz you in the knowledge areas:

basic union, general information, hiring hall, carpentry, shop, properties, electrics, audio, video, wardrobe, hardware identification, and practical application. Applicants must score eighty percent or better on each area to pass. Good luck.

--Local 470 examination committee

Copyright© 2021 edition

BASIC UNION KNOWLEDGE

1. What does I.A.T.S.E. stand for?
2. What branch of organized labor is IATSE affiliated?
3. When was the AFL-CIO founded?
4. What are three good advantages of being a union member?
 - 1.
 - 2.
 - 3.
5. Give a brief outline of "Collective Bargaining".

6. List at least 3 things organized labor has won for the American worker?
 - 1.
 - 2.
 - 3.
7. If you were in charge of a job which required more personnel, where and how would you get these additional hands?

8. If you were having trouble with the management on a job, or disagreed with the safety procedures you were asked to use, what would you do to straighten out the problem?

9. If you are going to be late or decide you can't make a call at the last minute, who should you contact and when, and in what order?

10. What resources do you have as a worker if you disagree with a department head or Job Steward on the job site?
 - A. Argue with him
 - B. See the Business Agent
 - C. Take a long lunch
 - D. Request a personnel complaint form from the Executive Board
11. In what month is the official Local 470 election usually held?

12. How often does Local 470 have a general membership meeting?

13. How long are Local 470's officers elected to serve?

- A. 4 years B. 3 years C. 2 years D. 1 year E. Until impeached

14. How much is currently withheld from Local 470 members' paychecks to pay for general expenses?

15. Explain the general concept of the IATSE Local #470 Steward Bill of Rights.

16. **True or False:** If you cannot attend the meeting of the official 470 election, you will not have the opportunity to vote.

17. **True or False.** All negotiated contracts for wages, terms, and conditions are the same for all employers and all venues.

18. I.A.T.S.E. International's office is located where?

19. List three reasons that are grounds for immediate dismissal from a job?

A:

B:

C:

20. In what year was IATSE Local 470 founded?

21. What recourse do you have as a worker if you disagree with a warning or late fine issued to you by a Steward?

22. Give a brief description of IATSE Local #470's geographical jurisdiction.

GENERAL

THE BASICS

- List the basic tools of a stagehand:
A: Miter saw, hammer B: Allen wrench, duct tape
C: Crescent wrench, gloves D: Multi-tool, night vision
- The first thing you should do when you arrive at a jobsite is:
A: Report to the Steward B: Call the Business Agent
C: Find catering D: Fill out W-2 form
- When working a show call, a Stagehand should come dressed in:
A: Boots, work clothes B: Gloves, jeans
C: Dark clothing D: T-shirt, slacks
- A "Trade Show/Expo" is:
A: A television production B: Pipe and drape
C: Bartering wages D: Video
- Explain why it is important to be on time for a job:
- The entryway to an arena floor is known as a:
- The half wall surrounding an arena floor is known as a:
- The proper time to arrive for an 8:00 AM call is:
A: 6:30 AM B: 7:50 AM C: 7:59 AM D: Whenever you feel like it
- True / False:** All trade show contracts are the same.
- True / False:** It is considered appropriate to text message or talk on your cell phone while working on a call.

11. Using the drawing below, insert the stage position for each number.

1. _____ 2. _____ 3. _____ 4. _____ 5. _____

6. _____ 7. _____ 8. _____ 9. _____ 10. _____

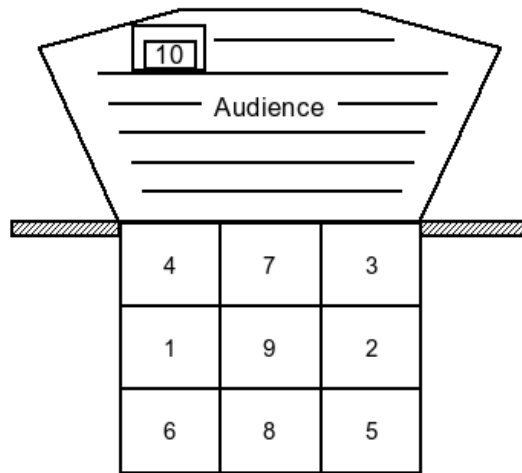

12. **True / False:** Catering is always provided to union stagehands.

13. When you have completed an assigned task, and do not know what to do next, you should:

A: Go home.

B: Stand around and wait for a new assignment.

C: Take a break

D: Inform your department head or road person.

14. **True / False:** Items left behind by traveling attractions are yours for the taking.

15. Your call time on a show call is "hour before half". The show is at 7:30. What time should you be ready for work?

16. What is the width of a standard trade show booth?

HIRING HALL

1. Disciplinary action within the Hiring Hall is done by whom?

A. The International Office

B. The Executive Board of I.A. Local 722

C. The Hiring Hall Conduct Board

D. The entire membership of the Hiring Hall

2. Dispatch Lists are generated how often?

A. Once a week

B. Once a month

C. Once a quarter

D. Once a year

3. To qualify for Dispatch list "A", you have must have accepted a minimum of _____ hours in one of the past two years.
4. In order to change the Hiring Hall Procedure and of Agreement of I.A.T.S.E. – Local 470, it would require:
- A. One meeting
 - B. Two Meetings
 - C. Three meetings
 - D. Once a year
5. The Hiring Hall Governance Board is made up of members of?
- A. The Executive Board of I.A. Local 470
 - B. The International Office
 - C. The entire membership of the Hiring Hall
 - D. Retired Local 470 members
6. **True / False:** If you are required to perform Jury Duty services after accepting a call you will be fined.
7. **True / False:** On an Emergency Dispatch Call, the Business Agent is required to hire Members of the Hiring Hall in Dispatch List order.
8. If you will be late arriving on a job site due to weather or traffic accident, who should you contact?
9. In the event an employer requires additional personnel after the start of a labor call, it is the responsibility of the _____ to fill that position.
10. If a member of the Hiring Hall is offered a job, they must respond by what action?
- A. By answering the phone.
 - B. Call the Business Agent within 4 hours.
 - C. By calling before 6:00 PM the next day.
 - D. By showing up on the job site.
11. **True / False:** To be a member of the Hiring Hall, you must have a completed Workers Agreement on file.
12. A member of the Hiring Hall may be removed from dispatch for the following reason(s): (circle ALL that apply).
- A. Union Membership.
 - B. The member is a convicted felon.
 - C. The member is too old.
 - D. Due to violations of the Conduct Policy.
 - E. Non-payment of Union dues or fines.
13. A Permit Worker will be paid Journeyman rates if they, (circle all that apply):
- A. Have achieved the required hours under contract
 - B. Is a Union member
 - C. Have passed the Journeyman Tests
 - D. Buys drinks for members.
14. **True / False:** Primary Stewards who are fulfilling their obligation to a particular Venue will not be negatively affected in regards to accumulated hours.
15. **True / False:** There is no appeal process for Disciplinary Action.
16. Appeals of a Disciplinary Action must be received within _____ days of that action.

17. **True / False:** If any section of the Hiring Hall Procedure and Agreement is found to be in violation of Local, State, or Federal law, the whole document is considered illegal?
18. **True / False:** An Employer has the right to deny employment to a member of the Hiring Hall for due cause.

SAFETY

1. The proper procedure for lifting is to lift with the:
A. arms B. back C. legs D. shoulders
2. The proper position for a Stagehand(s) to be in when pushing something up a ramp is:
A. in front/ behind B. the sides C. in front/ sides D. behind/ sides
3. Rigging ropes hanging from a Theatre grid should be:
A. coiled B. kept tight C. left alone D. maintained with light oil
4. When working with a fork lift, the responsibilities for safety fall on the:
A. fork operator B. people around operator
C. Steward D. operator/ workers
5. The most common injury for Stagehands is:
A. fatigue B. smashed fingers/ hands C. back injuries D. death
6. If you see a safety violation or unsafe work condition, you should:
A: Contact the Stage Manager. B: Put on your coat and go home.
C: Inform your Job Steward. D: Continue to work, however use extra caution.
7. If you are working over the heads of people, (on trusses, grids, loading rail's, etc), you should:
A: Make sure you have extra tools in case you drop one.
B: Empty your pockets and secure all tools you may need.
C: Don't chew gum, so you can yell "Heads", if you drop something.
D: Wear a Union shirt.
8. When using a Mobile Elevating Work Platform (MEWP) e.g. a Genie personnel basket lift, you should:
A: Use all outriggers and only on a level surface.
B: Listen to road crew instructions on questionable issues.
C: Remove the legs when positioned close to scenery.
D: Feel free to lean out of the basket, if the outriggers are secured.
9. If someone is injured at work, when do you notify the Job Steward?
A: Only if the injury is serious or draws blood.
B: At the end of your call.
C: Immediately, and in all cases.
D: If you think that it is important.

10. **True / False:** Road crews are allowed to override safety rules if they take responsibility.
11. When working on a step ladder, you should:
A: Not use the top two steps.
B: Stand on the top step if you have spotters.
C: Make sure at least three legs are in contact with the floor.
D: Use the ladder only if you have a safety harness attached.
12. If a stagehand feels uncomfortable with a job because of a safety concern, who should they contact?
13. If you see a rope tied off, and it is in your way, you should:
A: Untie it only long enough to get your job done.
B: Have someone hold the rope out of your way.
C: Do not touch the rope. Ask for assistance.
D: See if there is someplace else the rope can be tied to.
14. How far above the ground must you be before a safety harness is required?
15. Fire extinguishers are rated according to the materials they are meant to extinguish. What materials are in each classification?

Class A: _____

Class B: _____

Class C: _____

STAGE CARPENTRY DEPARTMENT

1. What is a sash?
2. What is a batten, and what is the standard batten size?
3. Name two places where endless lines are used.

4. In a counterweight system in our jurisdiction, which is the pull line to bring in the batten?
5. Explain the fundamental difference between a single and a double purchase counterweight system.
6. What does the head fly man have to remember about a double purchase system when computing weights?
7. In what applications are breast lines used?
8. If you had a unit too heavy to hang on one batten/pipe, what could you do?
9. Define the following terms:
 - Spot line:
 - Scrim:
 - Cyclorama:
 - Cable pick:
 - "West coast", [a drape]:
10. How do you level a batten?
11. If you are an electrician and need a certain batten brought in to the deck, to whom do you speak?
12. Explain the difference between a parallel and a platform.
13. How would you repair a rip in the muslin on a piece of scenery?

14. Name the indicated parts of a counterweight flying system:

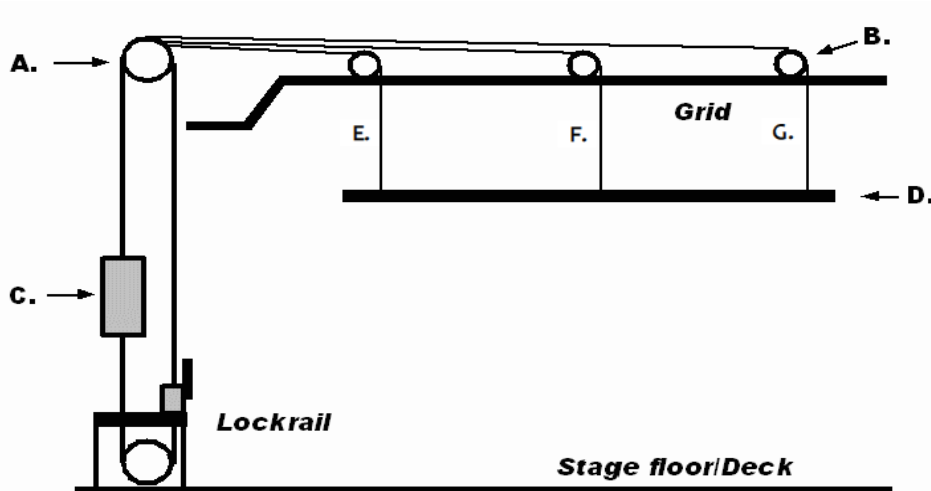

Name the indicated parts of a fly system:

A:

B:

C:

D:

Name the lines:

E:

F:

G:

15. **True / False:** When loading weight on married battens, load the first arbor completely before loading the second arbor.

16. Name five important knots used in theatre and their respective uses.

1. Knot: _____ Use: _____

2. Knot: _____ Use: _____

3. Knot: _____ Use: _____

4. Knot: _____ Use: _____

5. Knot: _____ Use: _____

17. If you drop a belaying pin from an elevated pin rail, what is the first thing you should do?

18. What tools should be carried to the grid of a theatre, and how should they be carried?

19. What is a snub?

20. How should a snub be used?

21. Explain the difference between a teaser and a tormentor?

Teaser:

Tormenter:

22. When the head fly man tells you to take a batten to pipe weight, what does this mean?

23. Explain what the “Dog” and “Knife” are on an Automated Deck.

Dog:

Knife:

24. Define the following rigging terms:

Pickle:

Span set:

Dead hang:

Bridle:

Basket:

25. What is the first thing you should do after securing the set piece to the dog with the knife?

26. What is the Proscenium of the Stage?

27. What are the primary duties of a Stage Carpenter?

28. What is a Kabuki Drop?

29. What would you use an axe handle or a pipe for on the fly rail?

30. Where would you place the Low-Trim spike mark and on which rope?

31. Where would you place the High-Trim spike mark and on which rope?

32. Why is it important for the Head Carpenter and the Head Fly-Man to maintain good communication?

33. After the fly-man calls out "Please add 21 bricks on line set 13", what do you do from start to finish?

SHOP DEPARTMENT

1. **True / False:** Parallel tops are generally made of 1/4" plywood.
2. Describe a coffin lock.
3. Describe a Cheeseborough.
4. What is the minimum length of a fastener (nail, screw, staple, etc.) that can be used when making a wood joint?
5. **True / False:** A butt joint is stronger than a mortise and tenon joint.
6. A rip in muslin should be patched on the _____ side of the flat.
Why?
7. What is the first thing to do when changing the blade in a power tool?
8. Below is a drawing of a step unit. Please label all parts as indicated.?

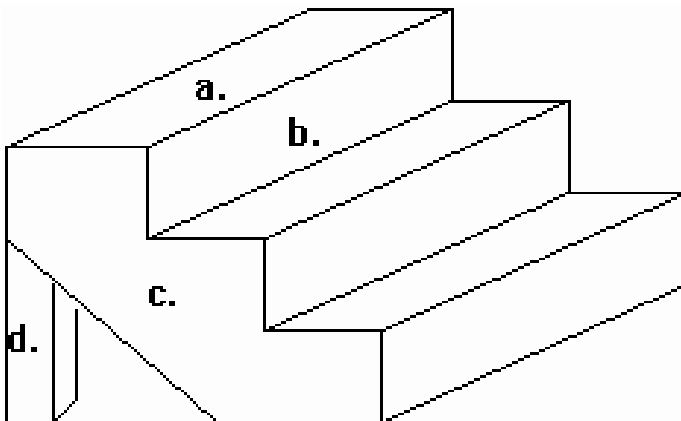

- a. _____
- b. _____
- c. _____
- d. _____

9. Why should the rails extend the entire distance of the bottom of the flat, instead of making the rails less wide and extending the stiles to the floor?
10. Circle one: Flame proofing should be added to the **upstage / downstage** side of a flat.
11. When describing a step unit, what is meant by the term "run"?
12. What is a scenery jack and how is it used?
13. Describe the difference between Broadway and Hollywood style flats.
- Broadway:
- Hollywood:
14. How many legs should be attached to a standard 4 x 8 platform?
15. Explain the difference between a dependent and an independent staircase.
16. Name two materials from which you could construct three-dimensional rocks.
Chicken wire and:
17. Name four types of joints used in set construction:
- 1.
 - 2.
 - 3.
 - 4.
18. When describing a step unit, what is meant by the term "rise"?

19. List three tools that could be used to cut a circle in 3/4" plywood.

- 1.
- 2.
- 3.

20. Below is a drawing of a flat. Please label all parts and draw in all missing items.

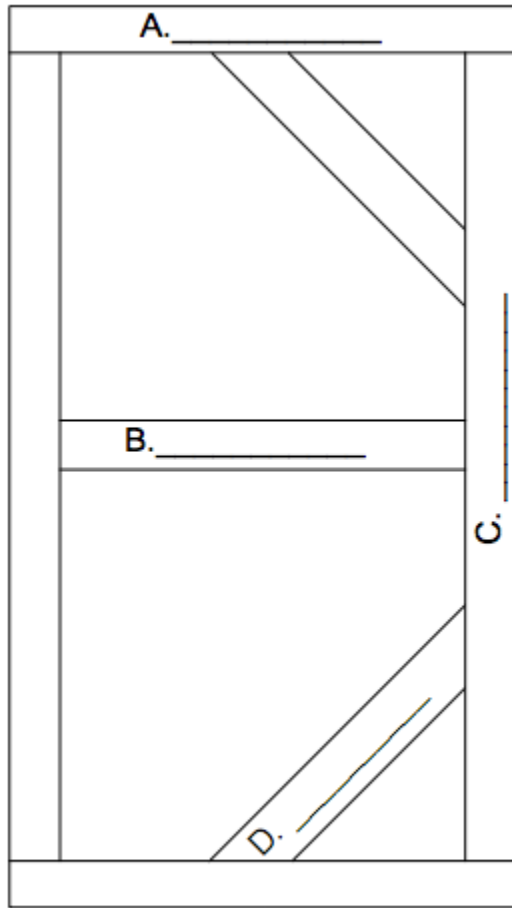

- A. _____
- B. _____
- C. _____
- D. _____

Don't forget to draw and label ALL missing parts!

PROPERTIES DEPARTMENT

1. Define the following types of props; give two examples of each:
 - A. Set props:
 - B. Trim props:
 - C. Set dressing:
 - D. Hand Props:
 - E. Personal props:
 - F. Greens:
2. What effects are parts of the props department? Give an example:
3. A production called for "snow". Of what material might it be made?
4. What method can be used to make snow fall?
5. The base falls off the nutcracker doll seven minutes before it has to make its entrance. What kind of glue should you use to repair it?
6. **True / False:** It is the job of the Props Department to sweep and mop the floor.
7. What should the props department do with sharp hand props?
8. After setting the piano for a recital, what should the prop master do to it next?
9. What should a prop master place on the speaker's lectern or on a table next to the lectern?
10. What is a break-away?

11. What is a practical?
12. Why or why not is it permissible to allow individuals to sit on show furniture?
13. **True / False:** It is the prop master's job to set the orchestra pit before the show.
14. What should the prop master do to a picture with glass in it, and why?
15. **True / False:** The prop master must deal with the on-stage intercom
16. How do you mark the placement of furniture or set pieces?
17. Name the three primary colors of pigment.
 - 1.
 - 2.
 - 3.
18. What is the first thing to do after painting a prop?
19. What are six precautions that should be taken when using spray paints?
 - 1.
 - 2.
 - 3.
 - 4.
 - 5.
 - 6.
20. Describe the job duties of a "runner"?
21. Define the following terms:
 1. Podium:
 2. Lectern:

22. Marley is the generic term for what?

23. Other than handling show props, list four other duties of a Prop person.

1.

2.

3.

4.

24. Define the following terms:

Wet Mop:

Dry Mop:

French Mop:

25. List 4 safety precautions that a props worker must keep in mind when handling weapons, and why?

1.

Why?

2.

Why?

3.

Why?

4.

Why?

26. Who is responsible for vacuuming carpeted areas in wardrobe quick change areas?

27. List at least 8 sanitary procedures that props workers must maintain when handling fresh food that will be consumed by performers on stage.

-

-

-

-

-

-
-
-
-

28. List at least 8 things to do if you are designated as fire watch on a performance that uses open flame or pyro on stage.

-
-
-
-
-
-
-
-
-

29. You are asked to create fake prop money for a show. What are the 3 strict rules under federal law governing the creation of fake money?

-
-
-

ELECTRICS DEPARTMENT

1. If you were a "House Electrician", what is the minimum size wire you can use to tie-in a 400 amp service?
2. If you were a "House Electrician", what is the minimum size wire you can use to tie-in a 200 amp service?
3. If you were a "House Electrician", what is the minimum size wire you can use to tie-in a 100 amp service?

4. If you were a "House Electrician", what is the minimum size wire you can use to tie-in a 50 amp service?
5. What is the minimum size wire you can use for a 20 amp service?
6. Name the colors of a 117/208 volt three-phase, five wire "wye" disconnect.

L-1:

L-2:

L-3:

Neutral:

Ground:

7. If you were a House Electrician with a 117/208 volt three-phase, five wire "wye" system, what voltage would you expect to find between the:

Red and Blue leg: _____ volts

Black and White legs: _____ volts

Red and Green legs: _____ volts

Green and White legs: _____ volts

8. What is the first thing an electrician should do after connecting the tails to a disconnect?
9. Using leg A, leg B, leg C, neutral, and ground to designate the terminations, in what order should a house electrician connect feeder cables to tails?

1. _____ 2. _____ 3. _____ 4. _____ 5. _____

10. After you have tied in rigging power as house electrician, the road electrician informs you that the motors are running backwards. Using the colors: Red, Green, Black, Blue, and White, which two colors could be inverted to rectify this problem?

11. How many of the following instruments can be safely controlled by a 2.4 kw dimmer:

750 watt ellipsoidals:

50 watt LEDs:

575 watt Source 4 PAR:

1.5kw far cycs:

12. **True / False:** Placing an electrical motor under the control of an SCR is acceptable if a phantom load is hooked up in parallel.
13. Explain the fundamental difference(s) between altering a cue in the stage and blind modes of a computer lighting console.
14. What capacity fuse would you use to protect a 2000 watt circuit?
15. Circle one: The first electric is the farthest (**Upstage / Downstage**) electric batten.
16. What device is used to connect multiple instruments together to one circuit or cable?
17. A standard 2-pin-and-ground connector has a _____ amp rating.
18. Match wire color to the correct pins on a standard 2-pin-and-ground stage connector (aka NEMA 5T-20).

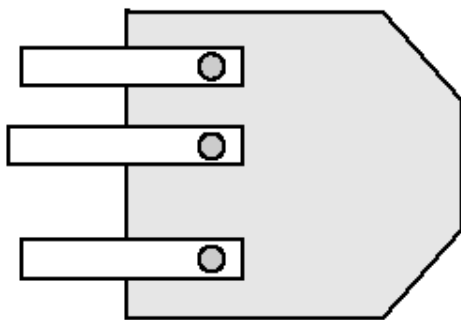

GREEN

BLACK

WHITE

19. Using “S” for a single-pole switch, “F” for a fuse, and “L” for a lamp, draw a simple and legal two-wire electrical circuit. Label one of the plug’s prongs “hot” and the other “neutral”.
20. How do you “spot” a Fresnel?
21. What are the instruments on booms and ladders in the wings called?

22. What is the best device to use to keep an electric batten from rolling?

23. Using R for red, G for green, and B for blue, indicate on the drawing below how a three-circuit Border light should be colored.



24. Some arc spots use a rectifier to convert _____ current to _____ current.

25. (Circle one): An arc lamp is dimmed (**electrically / mechanically**).

26. (Circle one): The load capacity of #18 wire is (**greater than / less than**) that of #22 wire.

27. **True / False**: A xenon follow spot should be shut down whenever possible to save the lamp.

28. **True / False**: The ground wire connects to the neutral buss at the company switch.

29. Name the three primary colors of light.

A. _____

B. _____

C. _____

30. Explain the difference between a dimmer and a control channel.

31. What is tracking, and how have electronic lighting consoles made tracking easier?

32. Lighting a scrim from the back makes it _____ and

lighting it from the front makes it _____.

33 Which theatrical material has the lowest reflectance value?

34. What is the difference between a boom and a rail?

35. Describe a Color Scroller:

36. Besides a power cable, what other connection is required to operate scrollers or moving lights?

37. Why should electric systems and sound systems use separate power supplies?

38. What is a fan-out or breakout?

39. What is a meat rack?

40. What are the functions of the three controls on top of a professional follow spot?

A:

B:

C:

41. Explain Color Temperature.

42. The _____ of the light is most important when designing television lighting.

43. A Sub-Master on a lighting console is used to:

44. What are pipe ends?

45 In a 6 x 9 ellipsoidal, the first number refers to:

The second number refers to:

46. Circle one: From the same distance, a **(6 X 9)** / **(6 x 12)** would produce a larger pool of light.
47. Circle one: From the same distance, a **(26 degree)** / **(36 degree)** would produce a larger pool of light.
48. During focus the LD tells you to "spin the bottle". You should:
49. During focus the LD tells you to "flag the instrument", You should:
50. What does LED stand for?

51. Match the following types of lights to the drawings below.

Fresnel Moving head Par can LED Flood LED Striplight Source 4/Leko

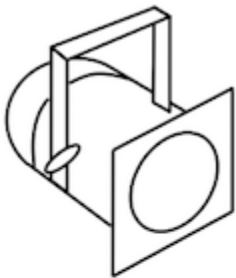

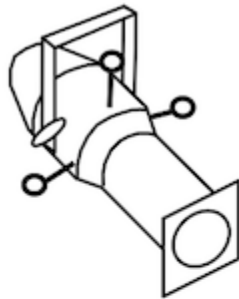

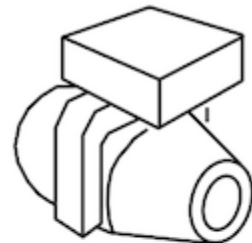

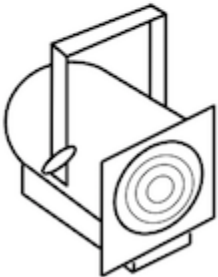

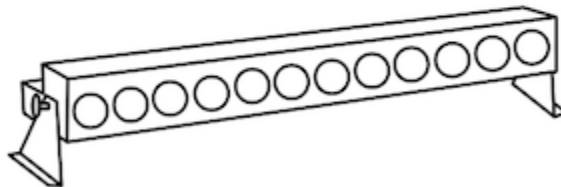

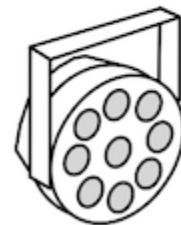

52. After hanging a moving head light, what four steps do you perform?

1:

2:

3:

4:

53. What is the current industry standard protocol used to control modern lighting equipment?

54. If you were asked to run a data cable to the output of a lighting console, scroller power supply, or DMX repeater/splitter, you would run the _____ end of the data cable.

55. You open a road box and find the feeder cables have male "Hot" connectors on top. You would run this end of the cable to the _____.

56. You have a female "Hot" Cam-Lock connector in your hand. This would plug into the _____.

57. Describe the differences between Circuit No., Dimmer No., and Channel No.:

Circuit No.:

Dimmer No.:

Channel No.:

58. A moving light "attribute" is?

59. The primary usage of the connector, shown below, in theatrical lighting is:



60. The primary usage of the connector, shown below, in theatrical lighting is:

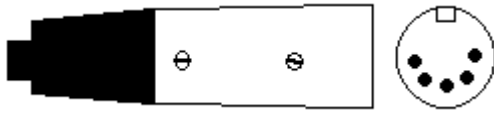

61. The production needs smoke or steam on stage. How might you accomplish this?

62. List three precautions when using dry ice:

- 1.
- 2.
- 3.

63. (circle one): The male end of a data cables is attached to the (**Input / Output**) of a device.

AUDIO DEPARTMENT

1. **True / False:** You should cut the grounding pin off a power cord to get rid of an annoying buzz.
2. Number the proper steps for turn on/turn off of a sound system.

TURN ON: _____ AMPS _____ EQ _____ TAPE/CD _____ MIXER

TURN OFF: _____ AMPS _____ EQ _____ TAPE/CD _____ MIXER

3. What are the two types of mic elements used most often?

1.

2.

4. **True / False:** You should test a mic by blowing into it.

5. Which side of a PCC mic should be pointed at the talent?

6. With a wireless microphone, what type of receiver performs best?

7. What does a direct box, (DI), do?

8. What happens to two identical signals that are 180 out of phase?

9. Why is the polarity of speaker connections important?

10. What are the three most important guidelines for feedback control?

11. Number the signal path from input to output.

_____ AMP _____ MIXER _____ SPEAKER _____ EQ _____ MIC

12. What is a Graphics Equalizer?

13. What does a Power Amplifier do?

14. What is clipping?
15. (**True / False**): You can connect in parallel as many speakers as you want to a power amplifier.
17. What does a crossover do?
18. What are the two types of crossovers?
19. What is a audio snake?
20. What is added to the signal path to make under-balcony speakers work properly?
21. What does MIDI stand for?
22. What can MIDI control besides keyboards?
23. Explain the difference of the Pre/Post button on a mixing console.
24. What do you do when finished talking on a headset, or before you take it off?
25. What is phantom power, and what is it's typical voltage?
26. What type of microphone requires phantom power.
27. **True / False**: You can run a Genie lift over a snake as long as the outer insulation is not damaged.

28. Circle one. You are standing onstage with a microphone cable in your hand. Which end do you run to the microphone? (**male / female**)

29. What is Dante and how is it used?

30. Using the illustration below, complete the drum set list, using the names specified, in typical wiring order.

DRUM SET INPUT LIST

1	
2	
3	
4	
5	
6	
7	
8	

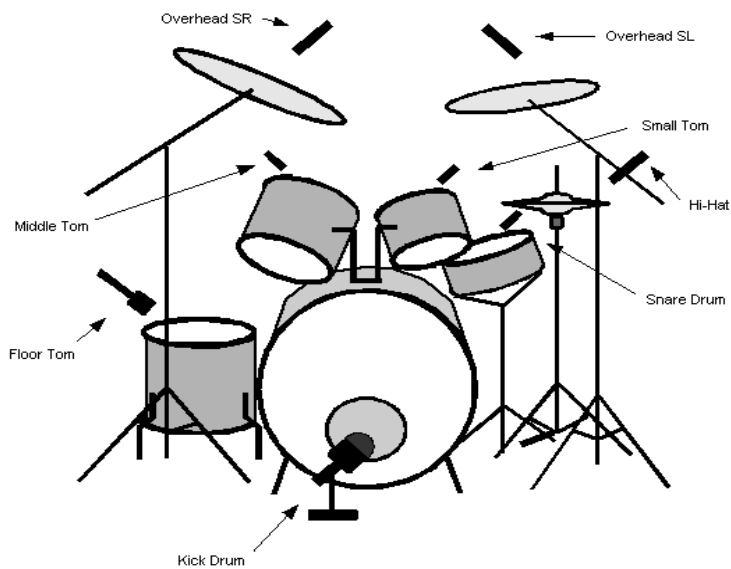

31.

Define each connector and its use

NOTE: connectors are not to scale.

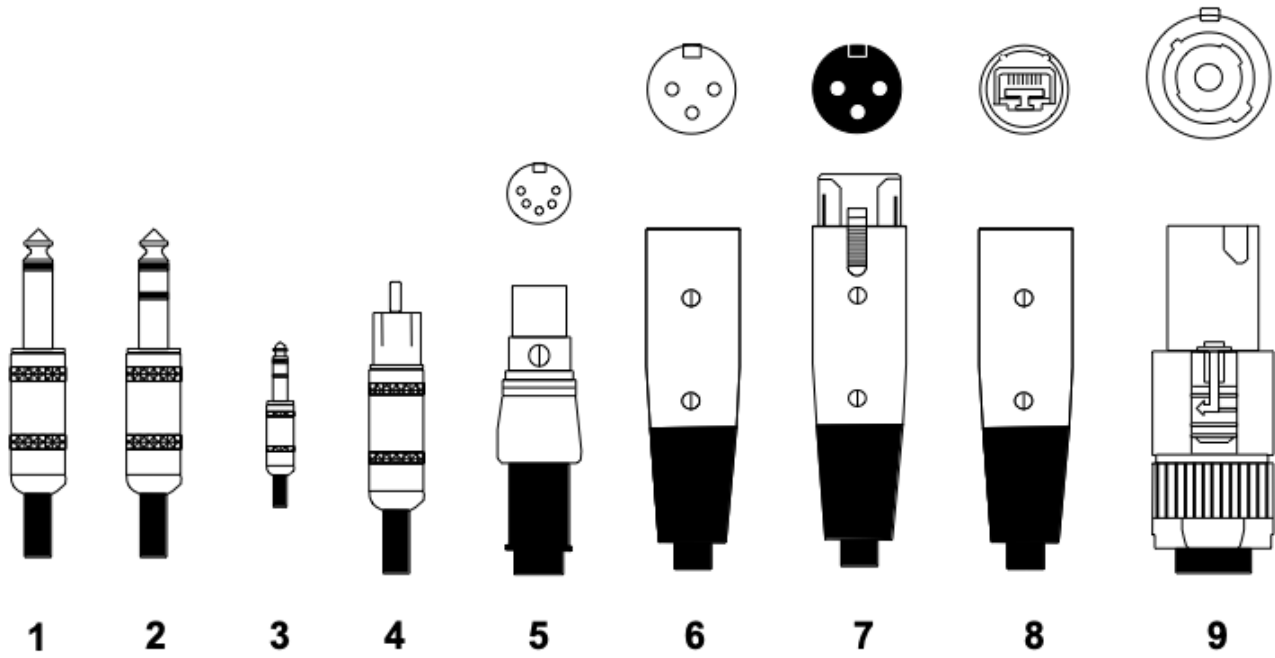

Connector

USE

- 1.
- 2.
- 3.
- 4.
- 5.
- 6.
- 7.
- 8.
- 9.

- 1.
- 2.
- 3.
- 4.
- 5.
- 6.
- 7.
- 8.
- 9.

32. What is this device and what is it for?

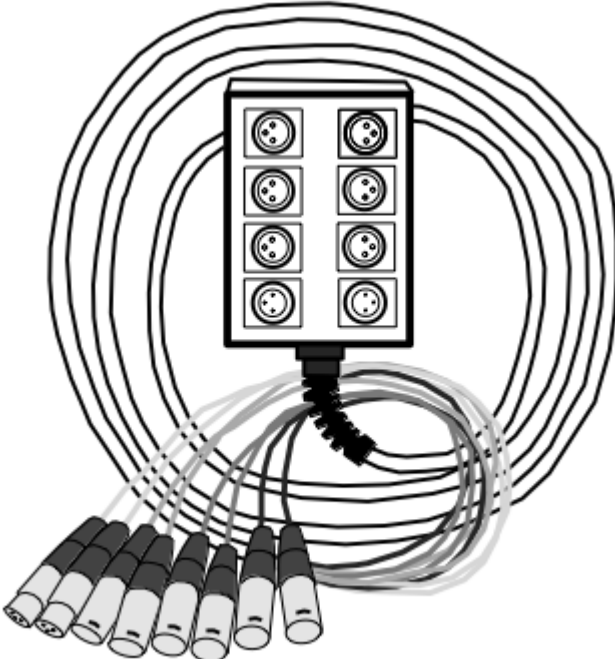

33. What does each of these knobs and faders do?

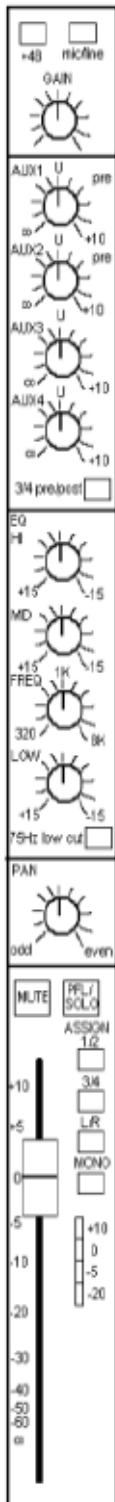

1. +48: PHANTOM POWER:

2. Mic/Line:

3. GAIN:

4. AUX 1-4:

5. 3-4 Pre/Post:

6. EQ. HI:

7. EQ. Mid:

8. EQ FREQ:

9. EQ LOW:

10. 75 Hz LOW CUT:

11. PAN:

12. MUTE:

13. PFL/SOLO:

14. ASSIGN 1/2 & 3/4:

15. ASSIGN L/R:

16. ASSIGN MONO:

17. FADER:

18. LED BARGRAPH:

34. What does each knob or fader do?

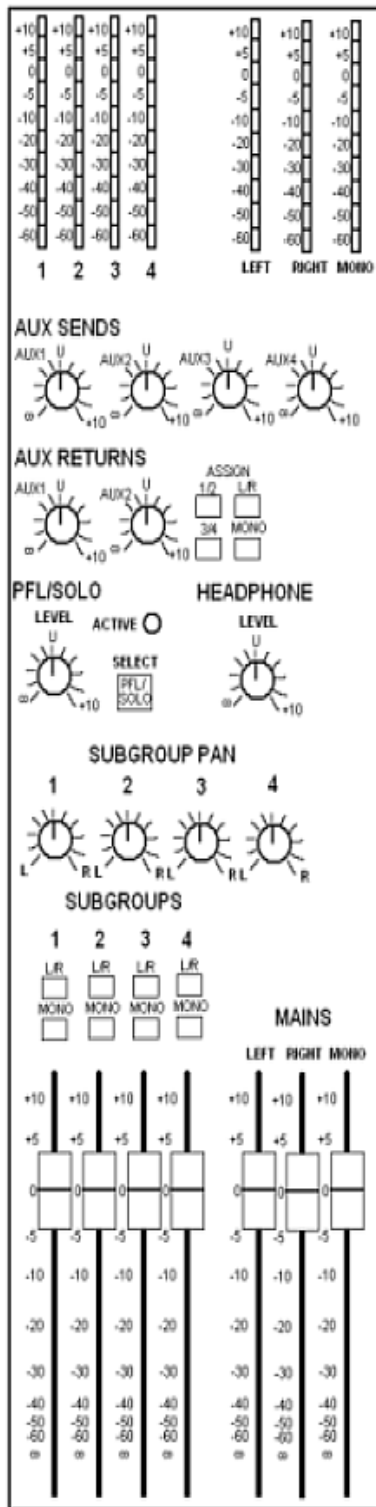

1. LED Bar Graphs:

2. AUX SENDS 1-4:

3. AUX RETURNS 1-2:

4. AUX ASSIGN:

5. PFL/SOLO:

6. HEADPHONE:

7. SUBGROUP PAN:

8. SUBGROUP ASSIGNS:

9. SUBGROUP FADERS:

10. MAINS FADERS:

35. WHAT DOES EACH INPUT JACK DO?

(Typical mixer, viewed from the back)

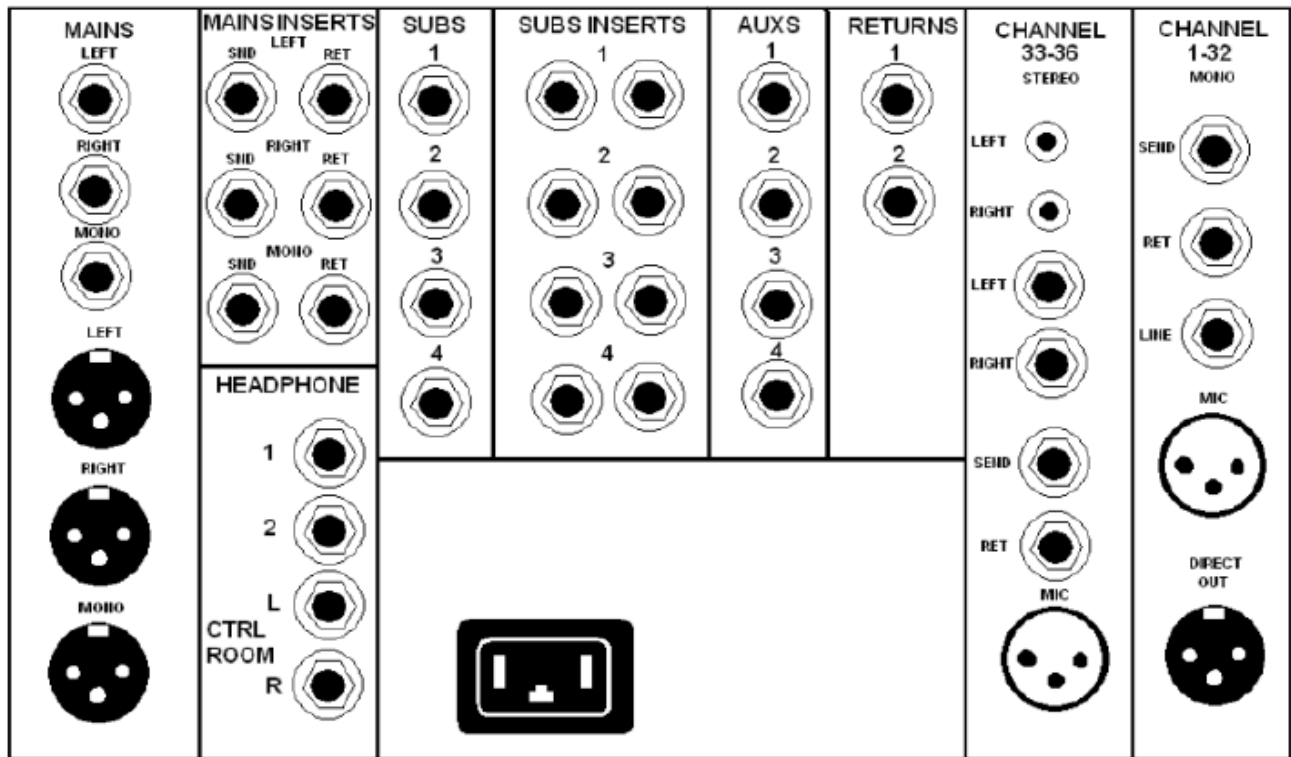

VIDEO DEPARTMENT

1. Name the following ports and connectors.



1.



2.



3.

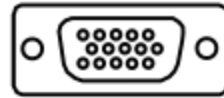

4.



5.



6.



7.

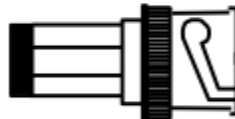
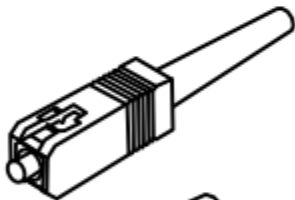

9.

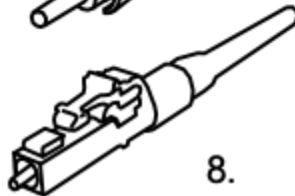

8.



10.



11.

1.	7.
2.	8.
3.	9.
4.	10.
5.	11.
6.	

2. A positive locking connector for video cable is called:

3. A "grip" on a video shoot is usually the person who?
4. What is the miniature microphone used to "mike" the "talent" called?
5. What is the duty of a Cable Page?
6. Using a typical three instrument set-up to light the video set, you're back-light, fill-light and key-light are 1000 watts each, what circuit or combination of circuits must you have to avoid tripping a 20 amp breaker?
7. What is the maximum wattage a 20 amp circuit will handle?
8. Drawn below is a basic video lighting scheme. Match the appropriate names for the various lights using three of the following possible choices?

Key:
 Bounce:
 Fill:
 Back:

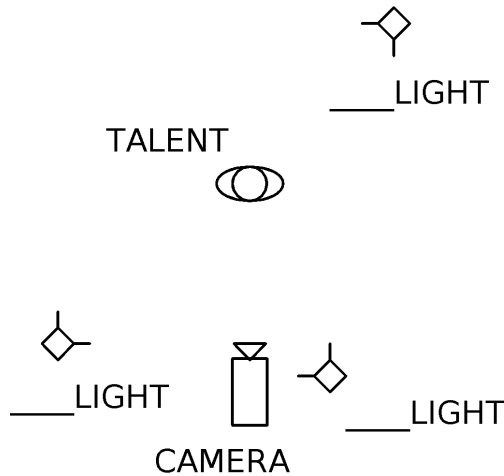

9. What is the most important thing to remember during a "take"?
10. The director has asked that the key-light be softened. What do you use to bring the intensity down?

11. Before each scene is shot the cameraman asks that a white card be placed in front of the lens. He flips some switches and white balances the camera. Why is this done?

12. In the video projection formula, $TD = TR * W$, define what each letter means.

TD =

TR =

W =

13. Video standards, in the United States, have two aspect ratios.

The analog standard is?

The digital standard is?

14. What is Chroma-Key?

15. Before attaching a projection screen to a folding frame, what should you do first?

16. **True / False:** You can hang a rear projection screen upside down without effecting the projected image.

17. What happens if you switch a projector from front projection to rear projection?

18. Define "keystoneing".

19. Explain the proper steps to follow to power up a projector.

20. Explain the proper steps to follow to power down a projector.

21. If requested to "Pan" a camera you would ...?

22. 15. "I-Mag" is short for:
23. Define a "Video Wall".
24. If requested by the Video Director to "Push-In", when you are operating a video camera, you would:
25. Why are FOH Video cameras on elevated platforms?
26. Why would you attach a 60:1 zoom lens on a video camera?

CONFERENCE A/V DEPARTMENT

1. A projection screen should be at least how high above the finished floor?
2. How might you correct a keystone error of a projection?
3. What is the correct start-up order for video projection?
4. A presenter has connected their PC laptop to the input, but a duplicate of his laptop's screen does not appear on the projector's screen. What keystroke combination will enable him to check the monitor send?
5. What does "PTZ" stand for when talking about cameras?
6. The lens throw ratio is 2.0, the screen is 10' across, how far away should the projector be?

7. An RGBHV cable will have what kind of connectors?
8. A rear-projection screen looks more (**grey / white**) in color than a front projection screen.
9. When multiple cameras are used for a live event, a _____ determines which signal is sent to the output.
10. When connecting a VGA cable to a laptop to playback a video, you must also connect _____?
11. What two items are the last to be done when setting up a projector/screen for AV in a conference room setting?
12. What is the name for a smaller display set up so the presenter can see what is being projected?

WARDROBE DEPARTMENT

1. What is the proper attire for a wardrobe person?
2. What are the duties of a wardrobe person?
3. Give five examples of possible assignments on a load-in.
4. Give five examples of possible assignments on a show call.
5. Give five examples of possible assignments on a load-out.
6. How can you remove wrinkles from velvet?

7. What are the basic tools that all wardrobe people should carry on all calls?
8. You are assigned to iron dress shirts. What should you ask the supervisor before you begin?
9. Why is ironing a shirt by: Collar, cuff and sleeve, other cuff and sleeve, yoke, front panel, back panel, other front panel the best method
10. How would you iron unidentified fabric?
11. How would you zip a tight body suit?
12. How would you free a stuck zipper?
13. What is a Wardrobe preset?
14. What is a “**dead costume**”?
15. What is a “**dresser track**”?
16. Define “**under dress**” and why is it used?
17. List at least two safety precautions when using a steamer.
 - 1.
 - 2.
18. What is a drop cloth?

19. What are “pit pads” and why are they used?
20. If you need tables and chairs for quick change areas, from which department do you get them?
21. As a general rule, how many irons or steamers can you plug into one outlet at a time?
22. What is a gondola?
23. What does it mean if you are told to hang costumes “chest left”?
24. How do you hang pants with a crease in the leg?
25. How do you hang pants with no creases in the leg?
26. Define the term “Puddling”?
27. You are dressing an ice skating show. What extra hand tool should you carry and why?
28. Why should you never use sewing room scissors on anything but fabric?

What will happen if you use a stitcher's fabric scissors without permission?

HARDWARE IDENTIFICATION

1.	25.	aa.
2.	26.	bb.
3.	27.	cc.
4.	28.	dd.
5.	29.	ee.
6.		ff.
7.	A.	gg.
8.	B.	hh.
9.	C.	jj.
10.	D.	kk.
11.	E.	ll.
12.	F.	
13.	G.	
14.	H.	
15.	J.	
16.	K.	
17.	L.	
18.	M.	
19.	N.	
20.	P.	
21.	R.	
22.	S.	
23.	T.	
24.		

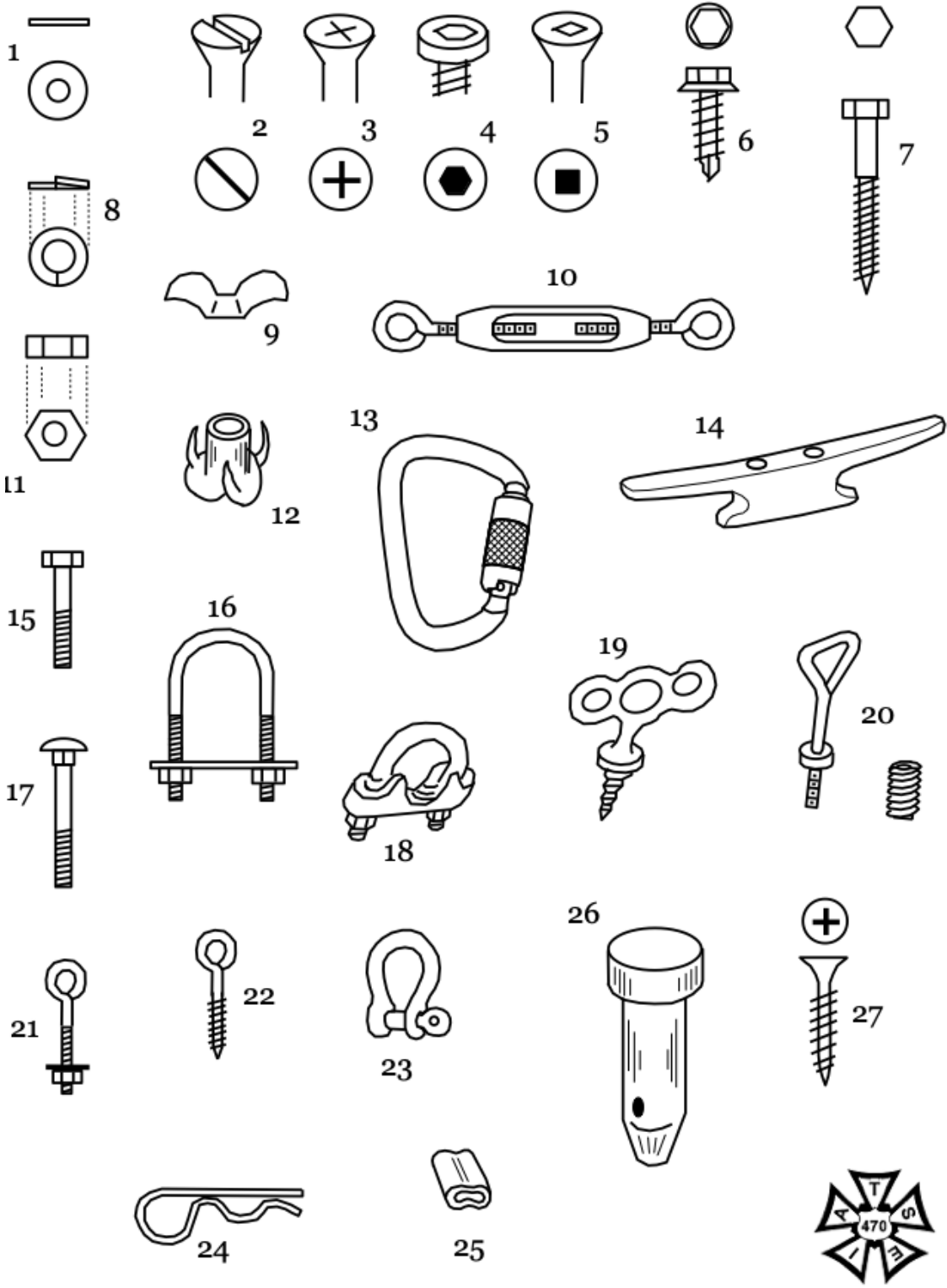

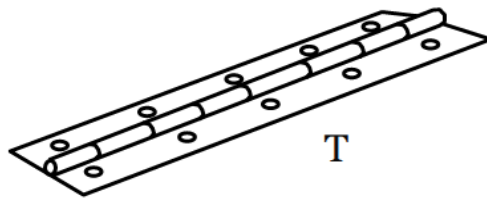
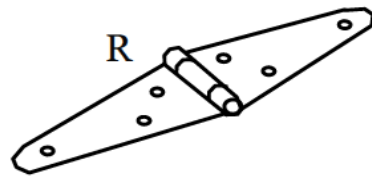
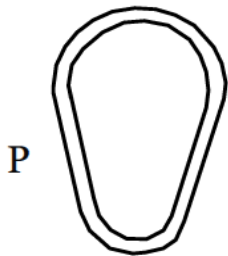
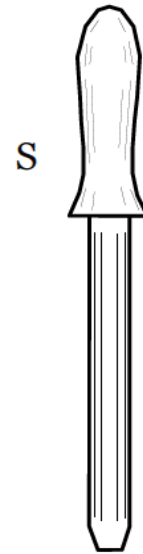
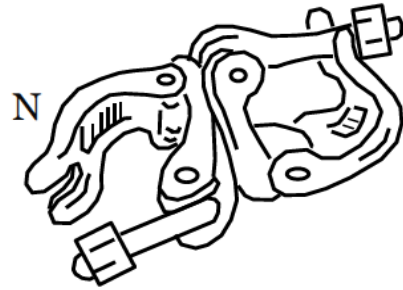
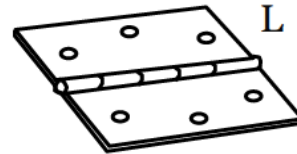
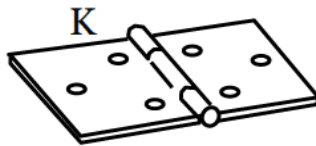
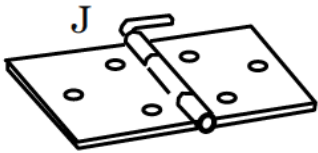
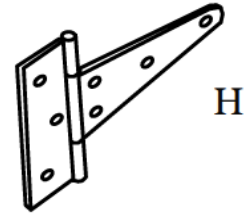
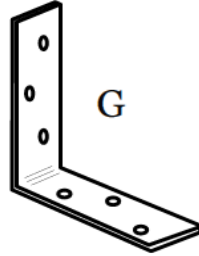
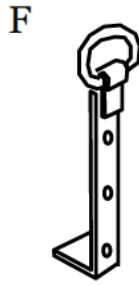
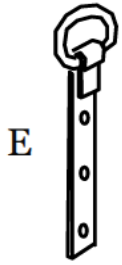
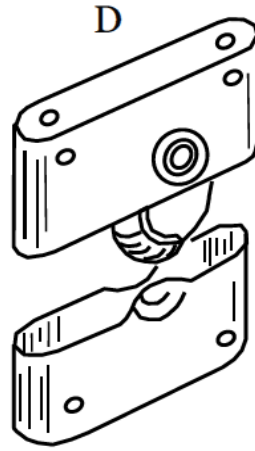
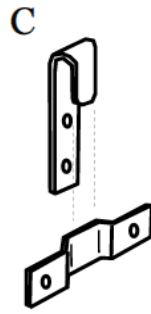
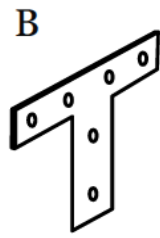
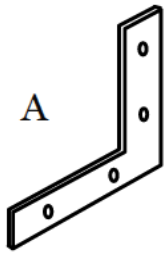

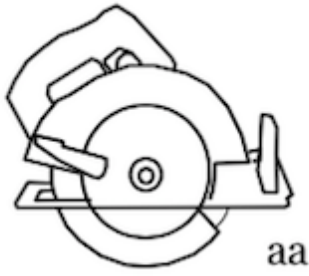

aa

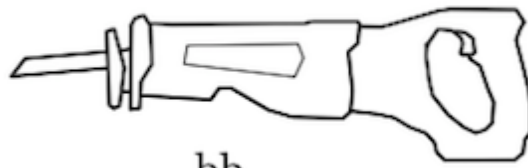

bb

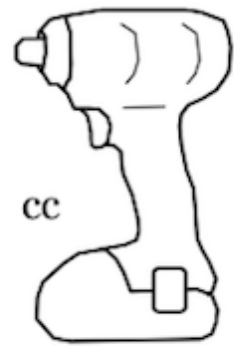

cc

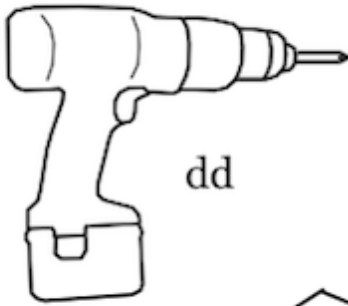

dd

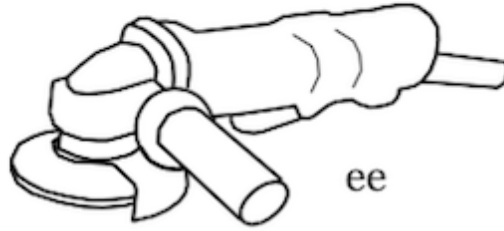

ee

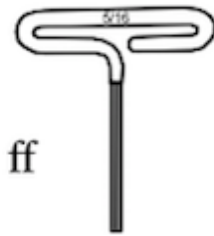

ff

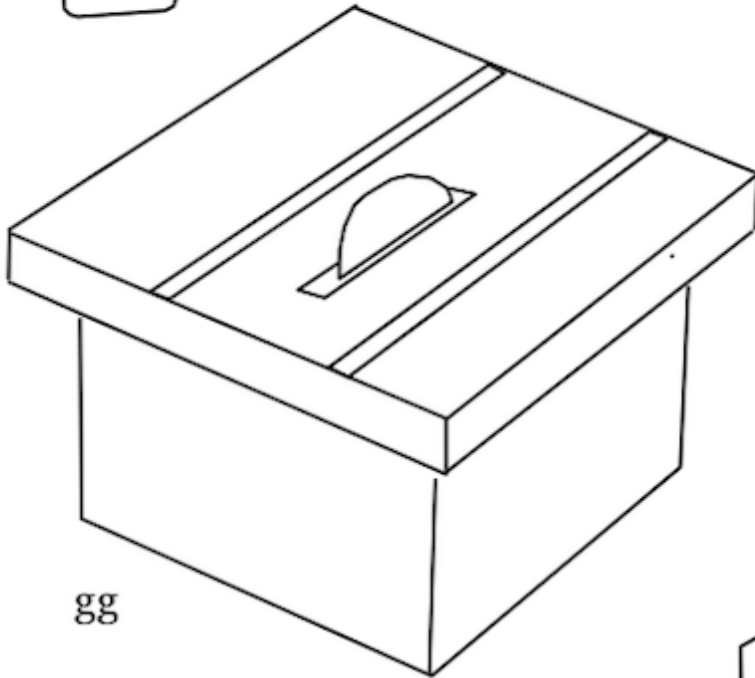

gg

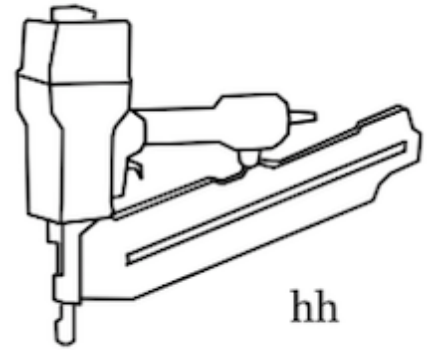

hh



ii

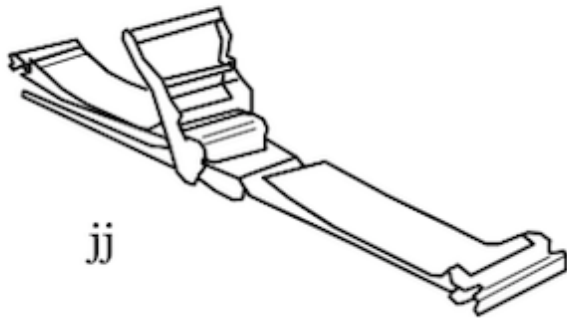

jj



kk

